

# Marine Fire Damper (Electrical / Manual Actuators)

## Model: FSD-EM

### Introduction

Marine Fire Dampers are used in ventilation systems to prevent spread of toxic smoke and hazardous gas between divisions.

### Description

Class A for Deck and Bulkhead Applications. Kyodo fire dampers satisfy for 60 minutes the requirements for stability and integrity according to Chapter II-2, Regulation 3 of **SOLAS** 1974, as amended. Tested according to **IMO** International Code for Application of **FTP** Fire Test Procedures Annex 1, Part 3.



### Complies to

- **Marine Equipment Directive 96/98/EC (MED).**
- **USCG (U.S. Coast Guard) approval number: Marine Fire Damper: 164.139/EC0575/6186**



0575/YY

YY denotes last two digits of the number of the year in which the damper is produced

### Applications

Marine, Oil & Gas, Process Plants and General Ventilation Systems.

### Features

- Robust construction
- Low casing leakage
- Low blade leakage
- Low airflow resistance

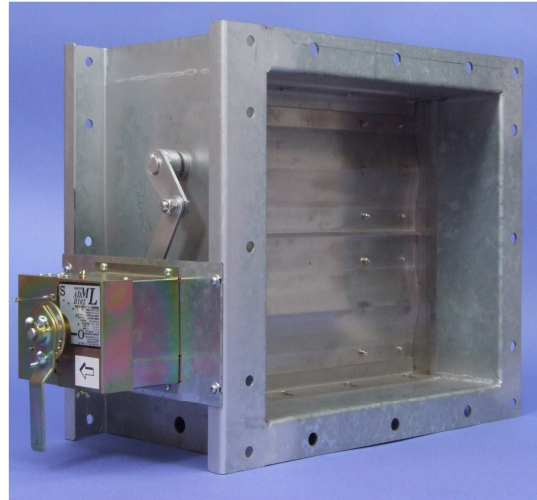

### Dimensional Limits

The minimum size is 150mm wide x 150mm high. The maximum single module size is 1,600mm wide x 1,600mm high.

### Construction

The damper frame is welded with integral 50mm folded flanges using 3-6mm thick galvanized steel. The drive side casing section is provided with a return flange to facilitate the mounting of the actuator bracket. For cases where there is difficulty to access the bolt holes behind the control enclosure, welded nuts will be provided.

The blades are double skin aerofoil type using 1.5mm thick SUS316 / SUS304 / Galvanized Steel are plug welded and bolted to 19mm diameter solid shafts.

Mechanical bushings are fitted on the non-drive side.

Damper with multiple blades are fitted with a linkage to provide an opposed motion. Robust blade links are welded to the drive shafts and connected together by flat bar. The linkage arrangement is contained within the flanges of the damper frame.

Round connection available on request.

# Marine Fire Damper (Electrical / Manual Actuators)

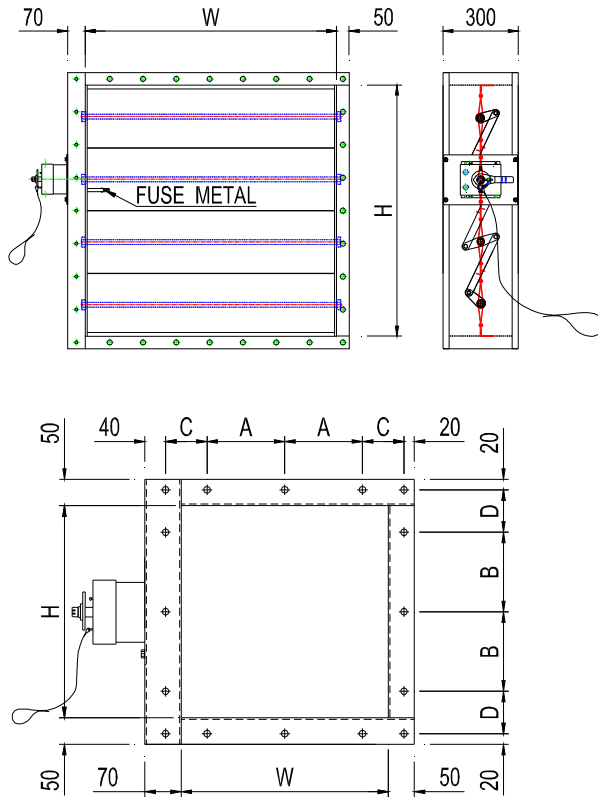

All dimensions are in mm

<b>A,B</b>	130 ( $W < 250$ )
	150 ( $W \geq 250$ )
<b>C,D</b>	Minimum 80, maximum 130

## Leakage Rates

Testing conducted by BSRIA on standard production single module dampers has achieved a mean leakage rate of

- 0.040 m<sup>3</sup>/s/m<sup>2</sup> at a differential pressure of 2,000Pa.
- 0.002 m<sup>3</sup>/s/m<sup>2</sup> at a differential pressure of 50Pa.

0.08 m<sup>3</sup>/s/m<sup>2</sup> at a differential pressure of 2,000Pa for NORSOK standard.

Lower leakage rates can be achieved upon request.

## Performance Tested

The test methods were taken from BS EN 1751:1999, comparable with those used in American standard AMCA 500-D-98. Leakage tests under BS1886, DW144 and UL555S also used the same methods.

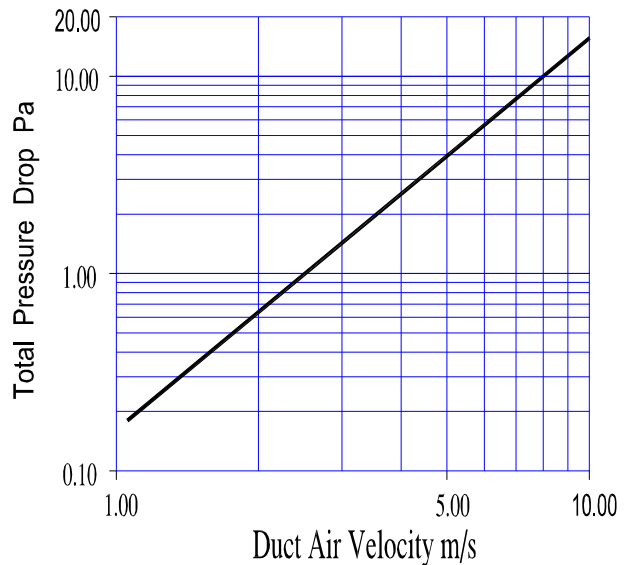
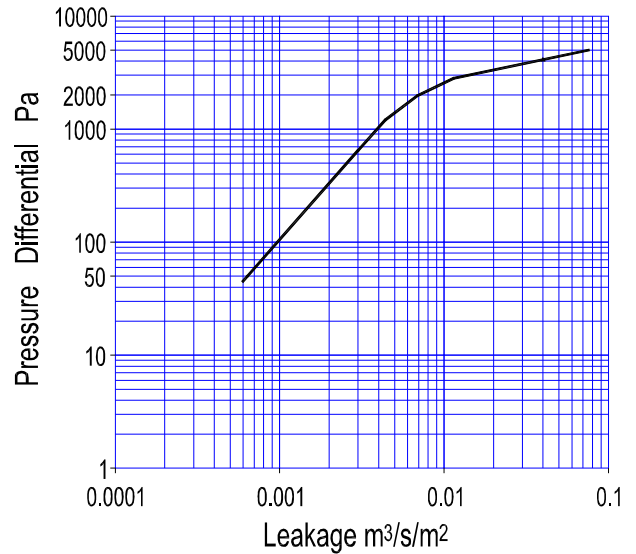

Data based on test conducted by BSRIA on a 1,000mm x 1,000mm damper.

Total pressure loss is measured across the damper when the blades are fully open.

# Marine Fire Damper (Electrical / Manual Actuators)

## Actuator

### Model:

- **ADS-B101 [Manual Reset]**
- **ADM-B102 [Manual / Electrical Reset]**

Closing	: Manual / Electrical / Fuse
Rated Voltage	: DC 24V
Operating Voltage	: DC 18V - 30V
Confirmation	: Operation confirmation signal from built-in microswitch
Fusible Link	: 72 degree celcius

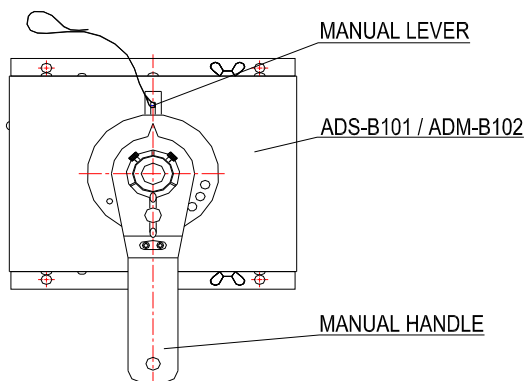

ADS-B101

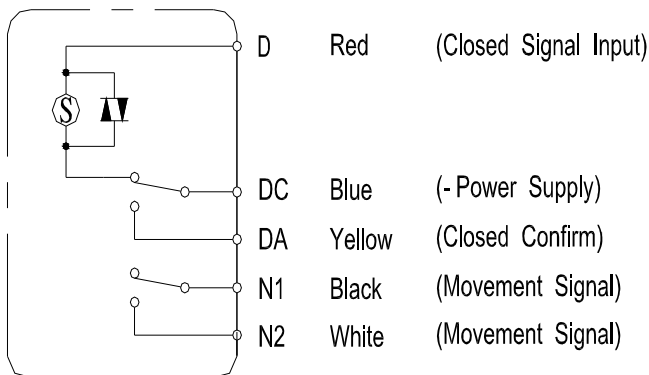

ADM-B102

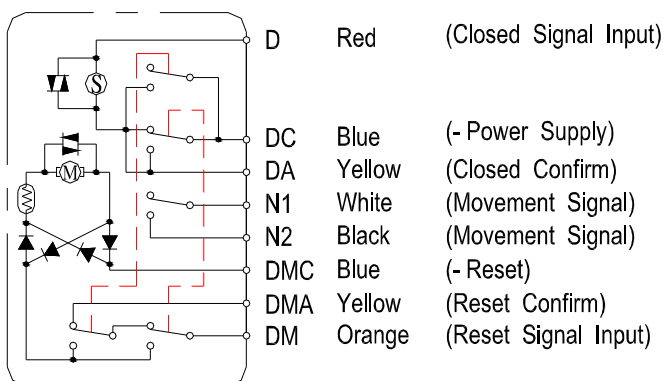

## Operation Method

The damper is fitted with an electrical actuator which enables rapid closing of the damper blades. It can be operated in three ways.

### 1. Manual Operation Mode

#### [ Closing ]

Pull the MANUAL LEVER. This actuates the spring to release (ADS-B101 /ADM-B102) causing the damper blades to close in 0.5sec.



#### [ Reset ]

Turn the MANUAL HANDLE counterclockwise until the indicator reaches position "O" on the scale, locking the damper blades.

### 2. Electrical Operation Mode

The electrical actuator closes/opens the damper blades rapidly once signal (AC/DC 24V) is received from control centre. Once the damper is closed / opened, confirmation signal and reporting signal will be sent out immediately.

### 3. Activation by Thermal Fuse Unit

A temperature above 72°C in the damper duct causes the temperature fuse to be melt. The shaft of the fusible link unlocks the fuse arm to activate the spring in the ADS-B101/ADM-B102, thus causing the damper blades to close in 0.5sec.